

# HASSLE-FREE INSTALLATION

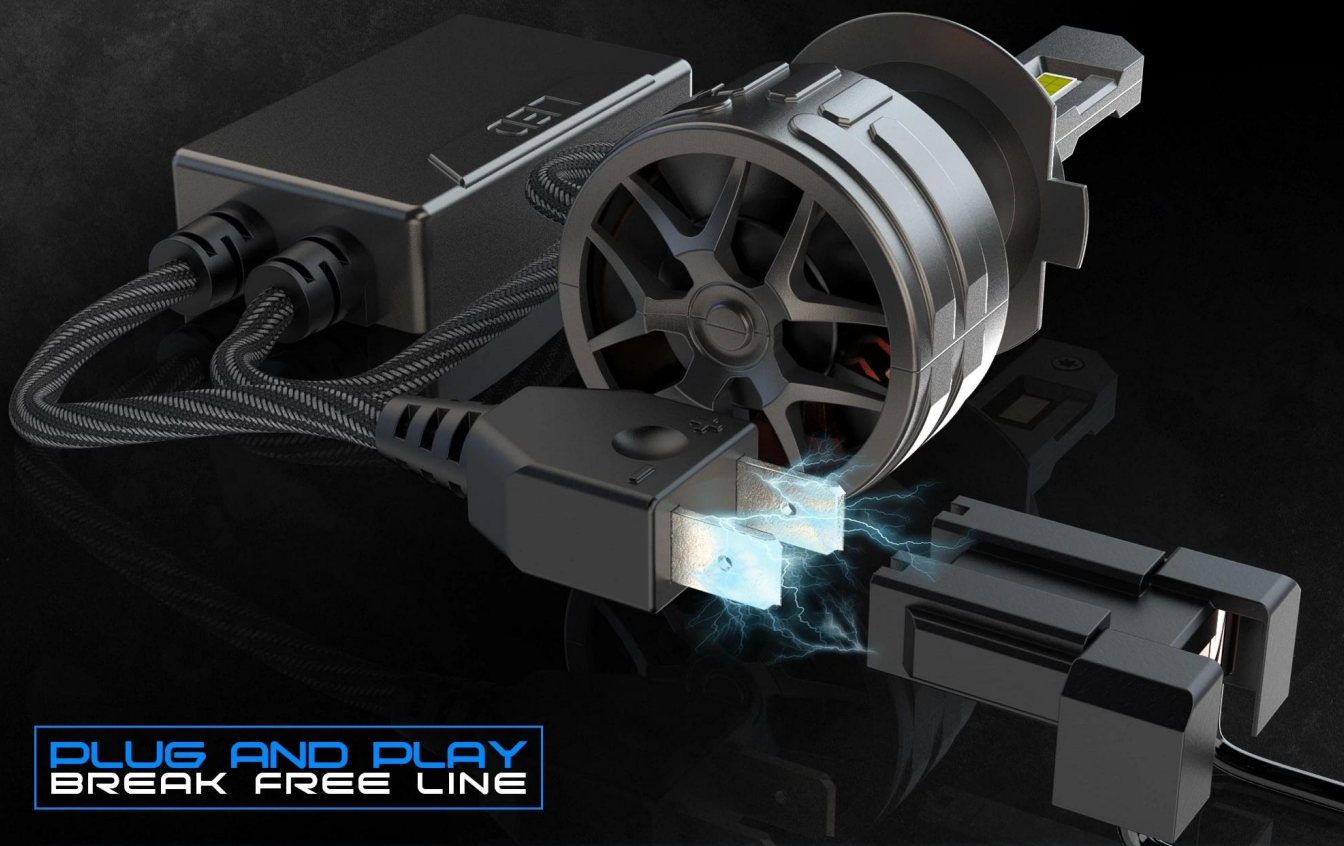

**PLUG AND PLAY**  
**BREAK FREE LINE**



# ALL IN CONTROL

## INTELLIGENT & POWERFUL

Built to ensure the LED bulbs to get a long-term and stable illumination



### EMC

Effectively prevent electromagnetic interference to electronic equipment such as car radios

### DRIVER LONGER

Intelligence temperature controller to ensure the LED headlight bulbs over 30,000+ hrs of brilliant continuous light.

### CANBUS UPGRADED

Dedicated LED driver eliminates flicker and ensures full power with very turn-on.

### TEMPERATURE CONTROL

Intelligent temperature control chip, effectively prevent temperature overload, more stable performance



# BEYOND

## THE ORIGINAL HALOGEN LAMP

NEW UPGRADE OF A NEW GENERATION OF LED CAR HEADLIGHTS

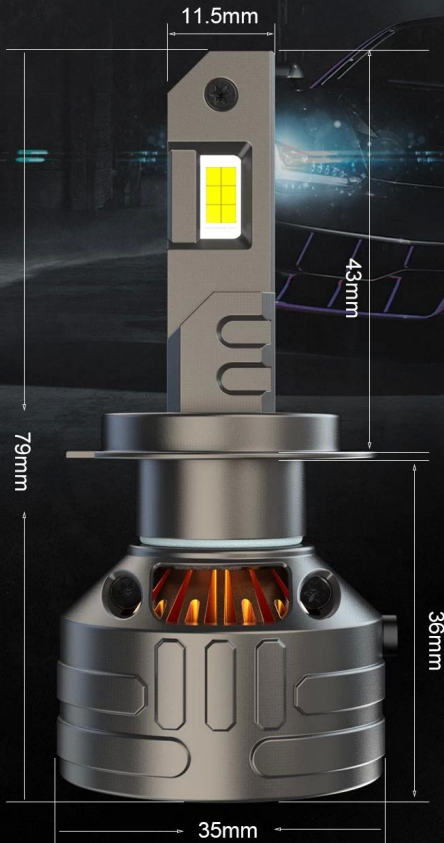

43mm

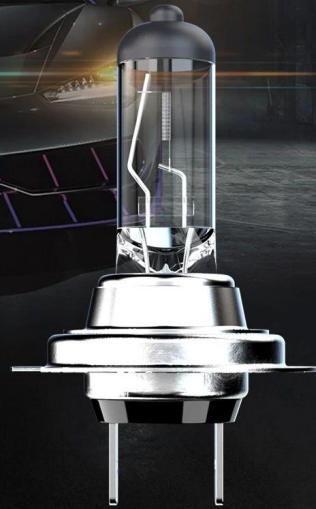

12000LM

200M

0.01S

30,000+ HRS

LUMEN  
DISTANCE  
STARTUP SPEED  
LIFESPAN

3200LM

100M

1S

3,000 HRS

# UPDATE VERSION

## BRIGHTNESS BOOST 150%

COMPARED WITH THE ORIGINAL CAR XENON LAMP

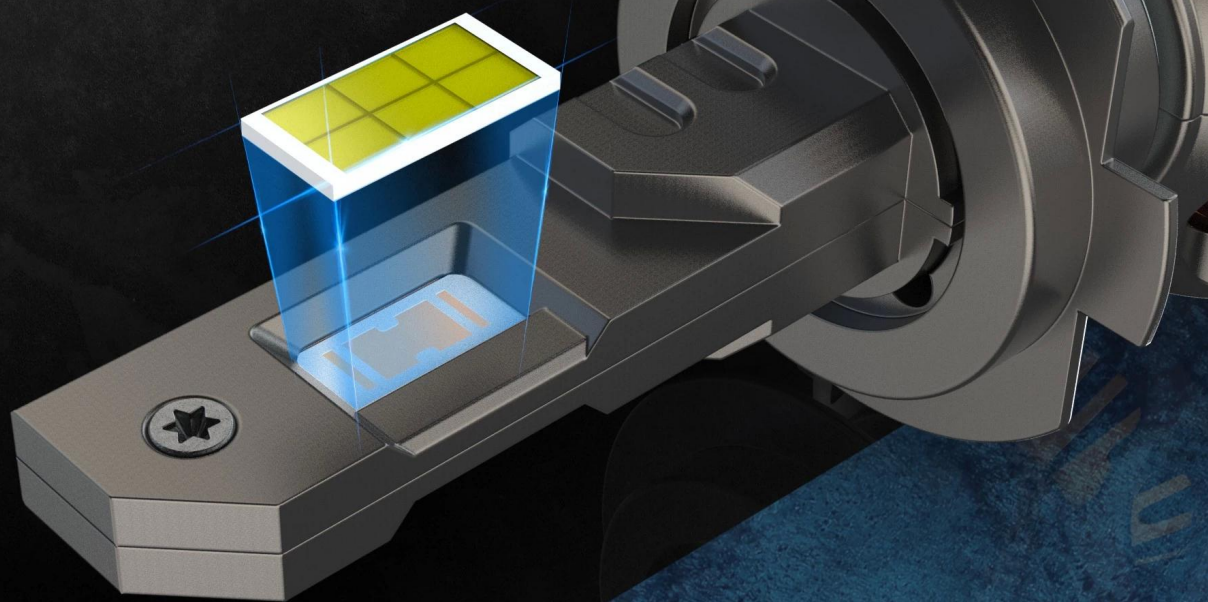

▶ Low beam



▶ High beam

# EFFICIENT COOLING SYSTEM

Gets rid of much heat from the led chipsets to ensure The longevity of up to 30000+ hours

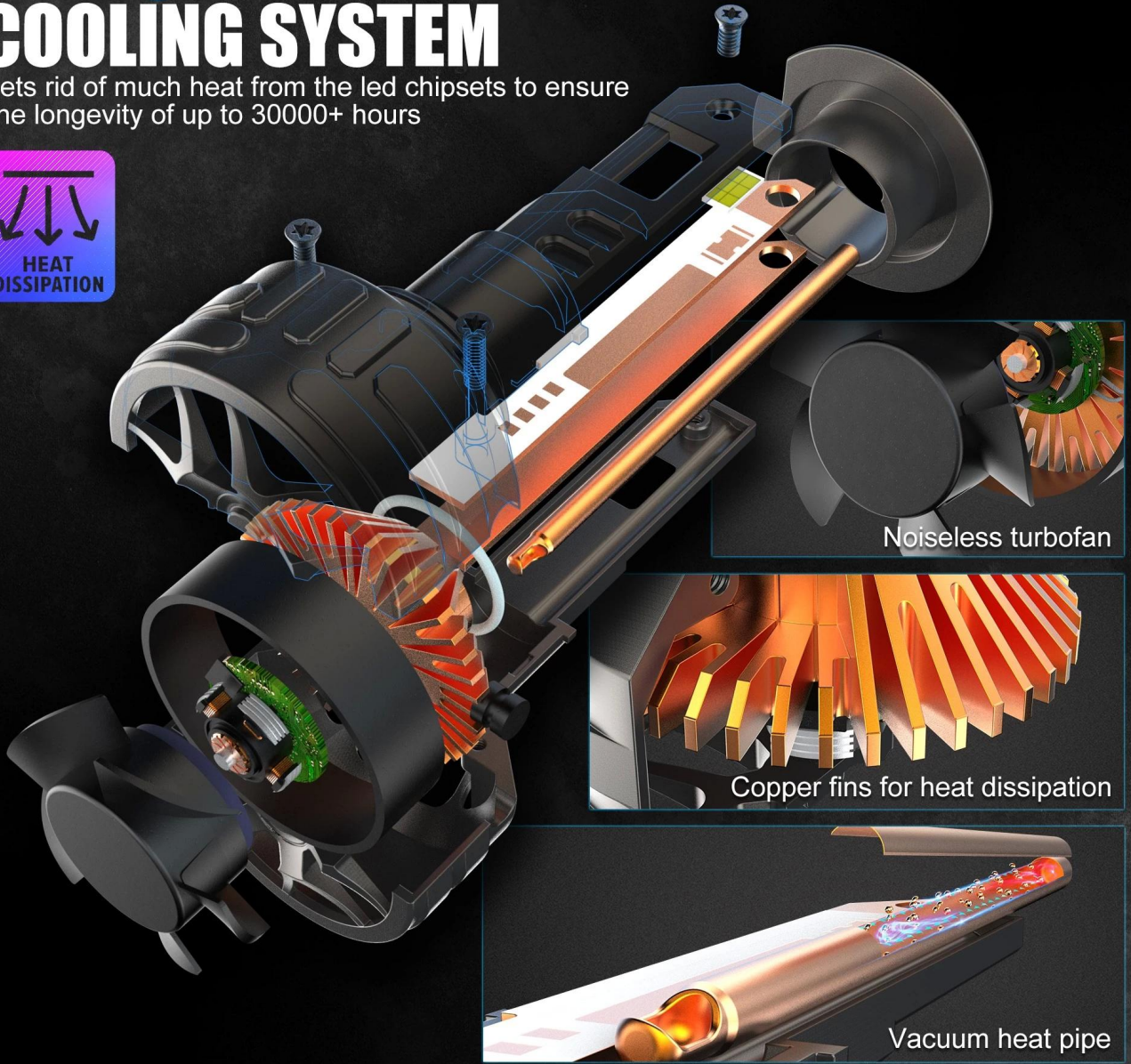

Noiseless turbofan

Copper fins for heat dissipation

Vacuum heat pipe

# 5 IMPROVES ADVANTAGE

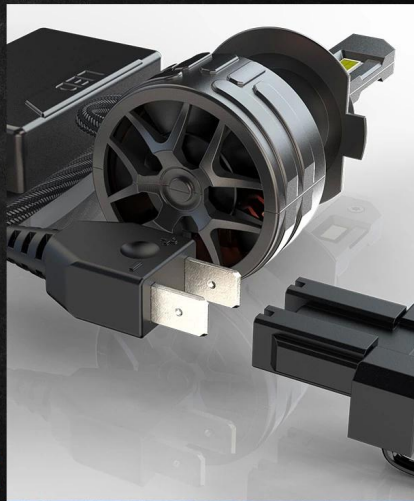

PLUG AND PALY

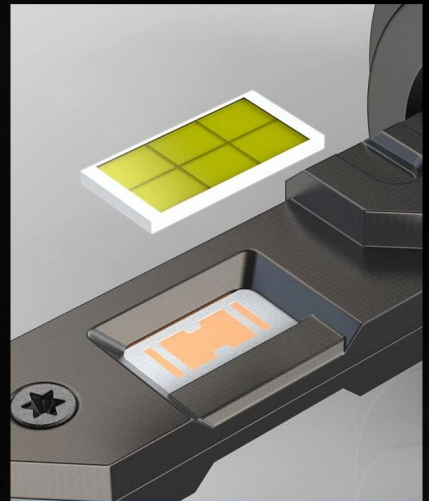

UPGRADED LED CHIP



NOISELESS TURBOFAN

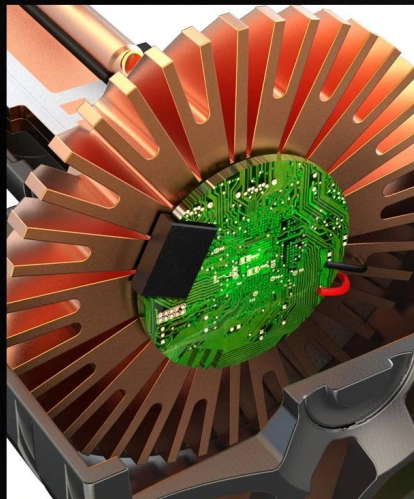

COPPER FINS FOR HEAT  
DISSIPATION



VACUUM HEAT PIPE